

4892 Compact Two-way Loudspeaker System

Array Series

Key Features:

- ▶ Perfect Array-Module Design
Horizontal Horn Pattern Matches Cabinet Angle
- ▶ High Technology Transducers
355 mm (14 in) Ultra-low Distortion Neodymium Woofer with Unique Gap Topology
38 mm (1½ in) exit, 100 mm (4 in) diaphragm Neodymium Compression Driver
- ▶ Secure Array Flying Ergonomics - S.A.F.E.™
Internal Steel Braces accept Optional Truss Module and Hardware
- ▶ Integrally Designed with JBL Array Series Controllers
Choose Analog, or Digital Controller for optimum system performance
- ▶ Versatile
Concert and Theater Reinforcement, AN Presentation, Speech Reinforcement

Array Series Systems

JBL's commitment of providing audio professionals the best tools for their work continues with the Array Series. JBL Array Series systems provide the ultimate performance for touring and fixed installations. The very compact 4892 provides smooth, predictable coverage and response from both a single enclosure and arrays of multiple enclosures. It combines ease of transport with the flexibility to fly or install quickly and safely. Integration of advanced design high power transducers, a new generation of horns, and advanced control electronics provides clearly superior performance. Reliability is designed in, without having to rely on intrusive signal processing.

Components

Array Series builds upon a solid foundation: more than 40 years of JBL transducer expertise and engineering. The 355 mm (14 in) low frequency transducer represents JBL's commitment to research. New technology includes a unique deep copper-sleeved gap low-distortion motor structure topology, with Vented Gap Cooling (VGC™) to produce the accurate reproduction at high power levels with minimal power compression. A new 38 mm (1½ in) exit

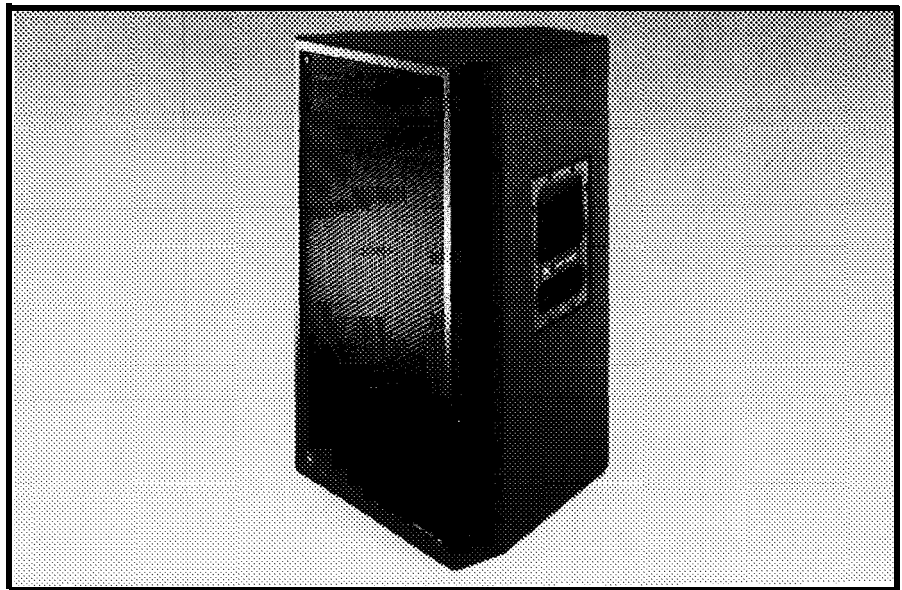

Specifications:

SYSTEM:	
Frequency Response ¹ (± 3 dB):	50 Hz - 18 kHz
Sensitivity ² :	98 dB (1 W, 1 m)
Recommended Amplifier Powers ³ :	
High Frequency:	300 W at 8 ohms
Low Frequency:	600 W at 8 ohms
Nominal Coverage:	45° horizontal, 35° vertical
LOW FREQUENCY TRANSDUCER:	
Nominal Diameter:	355 mm (14 in)
Nominal Impedance:	8 ohms
Power Rating:	600 W AES, 50 Hz to 500 Hz 2400 W peak
Voice Coil:	100 mm (4 in) edgewound aluminum ribbon
Features:	Ultra linear, neodymium magnet motor structure Vented Gap Cooling
HIGH FREQUENCY TRANSDUCER:	
Throat Diameter:	38 mm (1½ in) exit
Nominal Impedance:	8 ohms
Power Rating:	75 W AES, 1 kHz to 10 kHz 300 W peak
Diaphragm:	100 mm (4 in) pure titanium diaphragm
Voice Coil:	100 mm (4 in) edgewound aluminum ribbon
Features:	Neodymium magnet motor structure
HIGH FREQUENCY HORN:	
Type:	Optimized Aperture Flat-Front Bi-Radial
Material:	Die cast aluminum
Coverage:	45° horizontal, 35° vertical
ENCLOSURE:	
Type:	Vented, 45° included angle trapezoid
Material:	19 mm (¾ in), 13 ply hardwood
Flying System:	S.A.F.E. -JBL proprietary, modular, certified
Finish:	Black textured paint
Grille:	16 ga. perforated steel, foam backed
Connectors:	Parallel 8 pin Neutrik pins 1 ± LF, Pins 3 ± HF
Features:	Handles, 35 mm (1 3/8 in) aluminum tripod socket

¹Half Space measurement

²1 W is equivalent to 2.83 V into 8 ohms

³Recommended Power Amplifier ratings are a guide for amplifier selection considering normal program material and line voltage available to amplifiers, although lower power amplifiers may be utilized. The 4892 system is capable of greater peak power input.

▶ 4892 Compact Two-way Loudspeaker System

neodymium high frequency compression driver with Coherent Wave™ phasing plug and 100 mm (4 in) titanium diaphragm delivers low distortion response to beyond 20 kHz. A 45° Optimized Aperture Flat-Front Bi-Radial® horn² provides accurate pattern control over its entire bandwidth.

S.A.F. E.™ Secure Array Flying Ergonomics

Important for both portable and fixed installation applications is the ability to rig a cluster quickly, but with absolute safety. The 4892 has four internal steel braces that are ready to accept optional bolt-on truss modules. Any desired coverage can be quickly assembled using a few basic fittings. Ultimate break strength of this method exceeds 2700 kg (6000 lb). A complete line of hardware is available for any application.

Active Control

The ASC24 provides cost effective analog signal processing with simple setup. The DSC280 offers additional precision, flexibility, and user convenience available only in the digital domain. Both provide superior high level sound quality.

Enclosure

The system's 45° trapezoidal wedge shape helps optimize array performance. Extremely rigid 19 mm (3/4 in) 13 ply hardwood, a textured black paint finish, and a perforated 16 ga. steel grille form a durable package.

Applications

The 4892 is ideal for applications requiring high fidelity music reproduction at any SPL, or high intelligibility speech reinforcement. Size, shape, and performance allow "invisible" use.

¹U.S. Patent #4,308,932

GENERAL INFORMATION:

Dimensions: 628 x 394 x 362 mm
H x W x D (24 3/4 x 15 1/2 x 14 1/4 in)

Net Weight: 30 kg (66 lb)

Shipping Weight: 32.7 kg (72 lb)

OPTIONAL S.A.F.E. FLYING HARDWARE:

Truss Module: Cabinet flying truss

Shackle Mount: Attaches truss module to create lifting point

Connecting Bar: Connects 2 truss modules

Quick Release Pin: Locks shackle mount, truss module and connecting bar

Stacking Bracket: Vertically attaches 2 truss modules

TOP VIEW

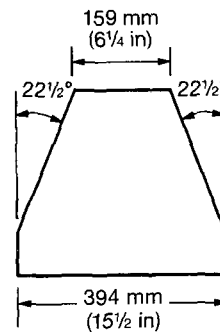

SIDE VIEW

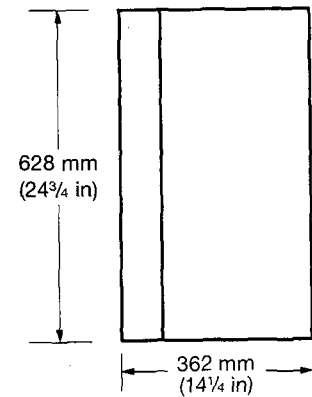

Optional S.A.F.E.™ Fittings

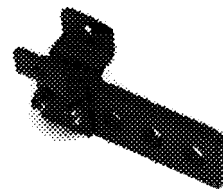

Shackle Mount
ASF-SM12

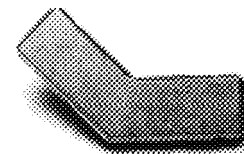

Connecting Bar
ASF-CB12



Stacking Bracket
ASF-SB12



Quick Release Pin
ASF-QRP

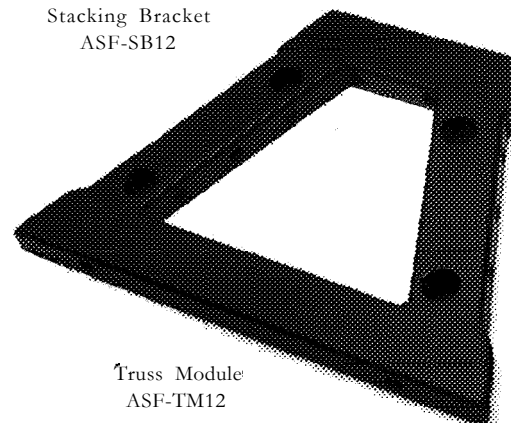

Truss Module
ASF-TM12

JBL continually engages in research related to product improvement. New materials, production methods, and design refinements are introduced into existing products without notice as a routine expression of that philosophy. For this reason, any current JBL product may differ in some respect from its published description, but will always equal or exceed the original design specifications unless otherwise stated.



JBL Professional
8500 Balboa Boulevard, PO. Box 2200
Northridge, California 91329 U.S.A.

H A Harman International Company

SS 4892
CRP 5M
10/96