



# MPC-XU Universal Crossover

## For JBL MPC and MPA amplifiers

### Owner's Manual and Installation Guide

## I. Description

The MPC-XU is a dual-channel universal crossover filter accessory for use with JBL MPC and MPA power amplifiers.

The MPC-XU is user configurable to fulfill these functions:

- active crossover
- bandpass filter
- subsonic filter
- ultrasonic filter

The MPC-XU allows independent filtering of the two audio channels. The choices are:

- high-pass filtering (selection of 19 frequencies)
- low-pass filtering (selection of 17 frequencies)
- bandpass filtering (selection of any combination of the high-pass or low-pass frequencies)

Each channel has an electronically balanced input and bypassable low-pass and high-pass sections. Each filter circuit uses a 4-pole (24 dB/oct) Linkwitz-Riley alignment.

An alternative to the MPC-XU, the MPC-X100 is preset at 100 Hz for use only as a subwoofer crossover.

The MPC-XU installs onto the amplifier's input card, where its settings are not easily accessible to the user. This makes the MPC-XU ideal for installed or rental sound systems, since it practically eliminates the danger of unauthorized tampering with crossover setting or incorrect crossover output connections, as well as the loudspeaker damage that may result from such user tampering.

Installing the MPC-XU involves soldering a 10-pin and a 12-pin header into corresponding holes on the input card, a process that only qualified technical persons should attempt. We recommend that you enlist an authorized JBL service center to perform the task. See the installation section of this manual for more information.

Figure 1 shows a block diagram of one channel of the MPC-XU:

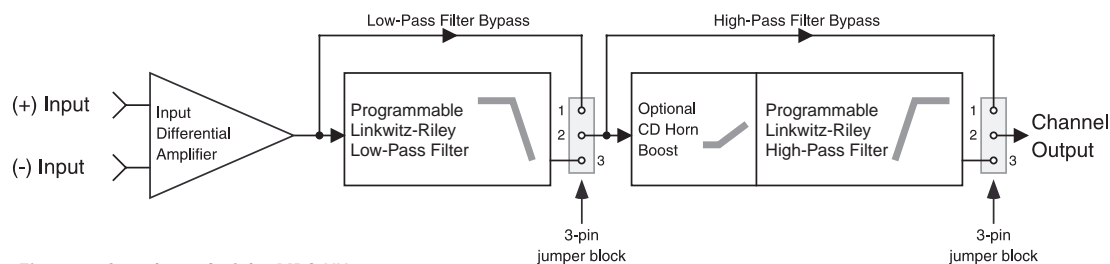

Figure 1. One channel of the MPC-XU



TD-000082-00  
Rev. B

## II. Installation



**CAUTION:** The MPC-XU contains active components which can be damaged by electrostatic discharge (ESD). Be sure to practice standard ESD precautions, and always ground yourself and your workstation before handling exposed circuit cards.

Installing the MPC-XU requires PC board soldering skills. Only qualified service technicians should attempt it. Any authorized JBL service center can perform the installation.

The MPC-XU installs on the amplifier input board of any JBL MPA or MPC amplifier.

### Tools needed:

Soldering iron

¼-inch (6.3 mm) nutdriver

Phillips screwdriver

Wire cutters

Rosin-core solder

Desoldering iron or other suitable desoldering equipment (*Do not use desoldering braid; it can damage the solder pads on the input board and might not remove solder adequately.*)



**CAUTION:** Preparing the input board for installation of the MPC-XU involves removing solder from feed-through holes on a 2-sided circuit board. Excessive heat can damage the solder pads you will be working on. Proper equipment and experience with desoldering delicate PC board circuitry is essential to successfully perform the procedure. Damage caused by improper installation is not covered under warranty.

- 1 Turn off the amplifier and disconnect the AC power cord from the AC source. Disconnect all cables from the amplifier's input panel.
- 2 Position the amplifier so the rear of the chassis is facing you. The input panel is located on the left side of the rear panel. See Figure 2a.

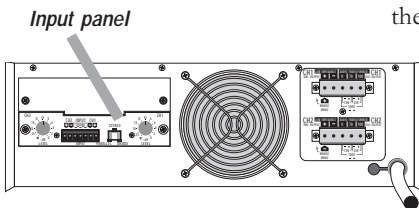

Figure 2a. The input panel's location on the rear panel of the amp

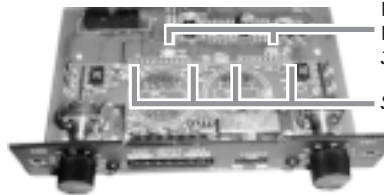

Figure 2b. The input panel (MPC)

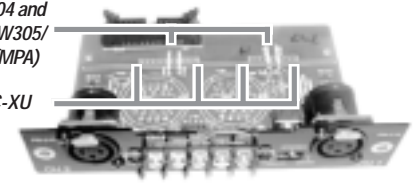

Figure 2c. The input panel (MPA)

- 3 Locate and remove the screws securing both the upper blank and the lower input panels to the rear side of the chassis (2 screws on each mini panel). The upper blank panel will simply drop off when its screws are removed.
- 4 Gently pull the lower input panel out from the amplifier. Once it is removed, you will notice a ribbon cable connecting the input PC board to the amplifier. Disengage the locking wing clamps on the ribbon header and carefully remove the ribbon head from the socket on the board. Now the input panel assembly is completely free from the amplifier.
- 5 Desolder and remove the wire jumper pairs indicated in Figure 2b or 2c.
- 6 Under where the jumpers were located, you'll find two rows of solder pad holes—one with 10 holes and another with 12 holes. Remove the solder from all 22 holes.
- 7 With the input panel facing you and the component side of the MPC-XU board facing away from you, carefully insert the header pins of the MPC-XU fully into the socket holes. Turn the assembly over and solder the MPC-XU in place. Make sure all the header pins are well soldered. Visually inspect for cold solder joints and verify that you have sufficient clearance to re-install the ribbon connector on the top side of the assembly. Finish by trimming the MPC-XU header pins as required.

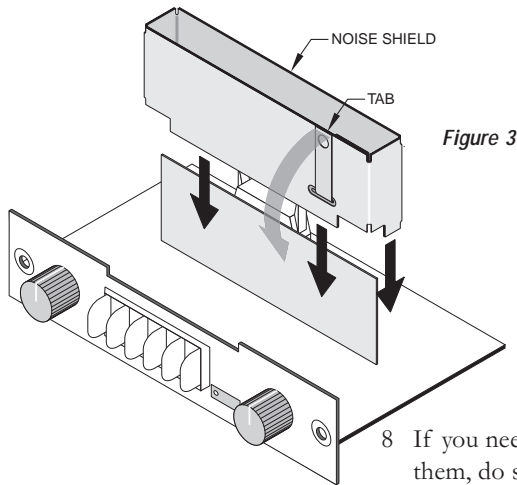

Figure 3

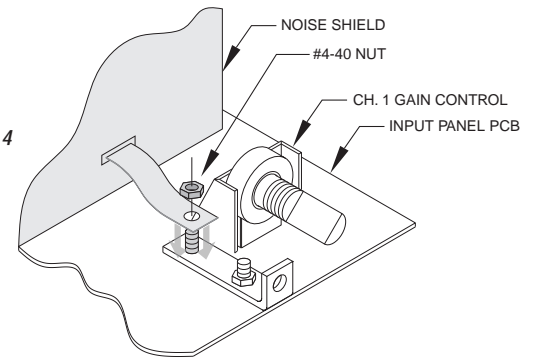

Figure 4

- 8 If you need to make any adjustments to the MPC-XU settings or if you need to record them, do so now, because the MPC-XU will be inaccessible once the noise shield is installed and the input panel is re-installed into the amplifier chassis. See Section III, “Programming the MPC-XU,” below.
- 9 Using a ¼-inch (6.3 mm) nutdriver, remove the outer 4-40 nut from the stud in the panel mounting bracket, next to Channel 1’s gain control potentiometer. Place the noise shield over the circuit board of the MPC-XU (Figure 3) and bend the grounding tab down so its hole goes over the stud. Re-install the nut, and tighten it securely (Figure 4).
- 10 Reconnect the ribbon cable to the input board connector. Press the locking clamp wings of the connector closed. You will feel them snap into place.
- 11 Carefully reposition the input board/MPC-XU assembly into the amplifier chassis and secure it by fastening the two mounting screws. Make sure the screws are tightened snugly, but do not over-torque them. Re-install the upper blank panel.

Installation of the MPC-XU is now complete, and the amplifier is now ready to be installed into the system.

### III. Programming the MPC-XU

The MPC-XU board has four switches, six 3-pin headers, and four SIP resistor network sockets (see Figure 3). All these are used for programming the module. The circuitry for the two channels is identical, so the switches, headers and sockets are divided between them: those designated by a 3-digit number starting in a 7 (switches S101 and S102, headers J101, J102 and J103; and SIP resistor network sockets RN102 and RN104) are for Channel 1, while those with a 3-digit number starting in a 2 are for Channel 2. The following instructions will use an *x* in place of the first digit, except where a specific channel reference is necessary.

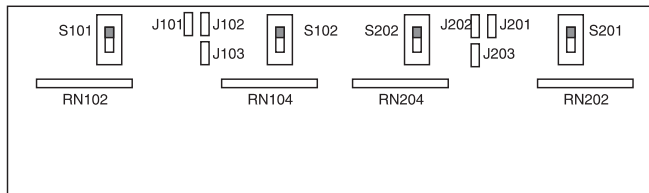

Figure 5. The MPC-XU’s switches, jumpers, and resistor networks.

#### Setting input operating mode on amplifier or input card

The input board or accessory on which the MPC-XU is installed has provisions—switches or headers—for setting the operating mode of the amplifier. In the signal flow, the MPC-XU is located *after* these switches or headers, so its operation is affected by the mode setting.

**Stereo or Parallel Mode Operation**—If the amplifier is to be used in stereo or parallel modes, configure both channels of the MPC-XU accordingly.

**Bridged Mode Operation**—If the amplifier is to be used in bridged mono mode, bypass Channel 2 of the MPC-XU and use only Channel 1’s input and processing.

1 Pins 1 & 2  
2 shorted together  
3

1 Pins 2 & 3  
2 shorted together  
3

1  
2  
3

## Bypassing the filters

To completely bypass the filter circuitry of a channel, set the jumpers on both Jx01 and Jx02 across pins 1 and 2, which are the upper two pins on their headers (see Figure 6). Note: If you neglect to place jumpers on either header, no signal will pass on that channel.

Figure 6

Switch Sx01 in "x1" position	Switch Sx01 in "x10" position	Resistor network in RNx02
80 Hz	800 Hz	120K
100 Hz	1000 Hz	82K
120 Hz	1200 Hz	68K
160 Hz	1600 Hz	56K
200 Hz	2000 Hz	47K
250 Hz	2500 Hz	33K
500 Hz	5000 Hz	18K
800 Hz	8000 Hz	12K
1600 Hz	16000 Hz	5.6K
2000 Hz	20000 Hz	4.7K

Low-pass filter frequency table

Switch Sx02 in "x1" position	Switch Sx02 in "x10" position	Resistor network in RNx04
20 Hz	200 Hz	120K
30 Hz	300 Hz	82K
40 Hz	400 Hz	56K
50 Hz	500 Hz	47K
80 Hz	800 Hz	27K
100 Hz	1000 Hz	22K
120 Hz	1200 Hz	20K
150 Hz	1500 Hz	15K
200 Hz	2000 Hz	12K
400 Hz	4000 Hz	5.6K
500 Hz	5000 Hz	4.7K
800 Hz	8000 Hz	2.7K

High-pass filter frequency table

## Programming the low-pass filter

**Bypass/enable header**—To use the low-pass filter, set the jumper on Jx01 across pins 2 and 3, which are the lower two pins on their header. But if you do not wish to use the low-pass filter and want to bypass it instead, set the jumper across pins 1 and 2.

**Setting frequency**—To set the corner frequency (at which the output is 6 dB down) of the low-pass filter section, choose the appropriate resistor network value and switch setting for RNx02 and Sx01, respectively. (Sx01 is a  $\times 10$  range switch. In its upper position, the frequency range is  $\times 10$ ; in the lower it is  $\times 1$ .) Use the low-pass table to select the right combination. See the appendix of this manual for keys to identifying the correct resistor network.

**Inserting the resistor network**—If there is a resistor network already installed in the socket, carefully pull it straight out. Insert the pins of the new resistor network into the socket holes and carefully press the network into the socket. Be careful to avoid bending the pins of the resistor network. Orientation of the resistor network is unimportant, as long as all 8 pins are well seated in the socket.

## Programming the high-pass filter



**Bypass/enable header**—To use either the high-pass filter or the constant-directivity horn equalization, or both, set the jumper on Jx02 across pins 2 and 3, which are the lower two pins on their header. But if you do not wish to use either one of these functions and want to bypass them, then set the jumper across pins 1 and 2.

**Setting frequency**—To set the corner frequency (at which the output is 6 dB down) of the high-pass filter section, choose the appropriate resistor network value and switch setting the RNx04 and Sx02, respectively. (Sx02 is a  $\times 10$  range switch. In its upper position, the frequency range is  $\times 10$ , in the lower it is  $\times 1$ .) Use the high-pass table to select the right combination. See the appendix of this manual for keys to identifying the correct resistor network.

**Inserting the resistor network**—If there is a resistor network already installed in the socket, carefully pull it straight out. Insert the pins of the new resistor network into the socket holes and carefully press the network into the socket. Be careful to avoid bending the pins of the resistor network. Orientation of the resistor network is unimportant, as long as all 8 pins are well seated in the socket.

**CD Horn Equalization (Boost)**—In addition to enabling the high-pass filter at Jx02, if you opt for CD horn equalization you must place a jumper at Jx03 as well. The MPC-XU offers two equalization curves for CD horn correction:

- For +6 dB of boost at 20 kHz, place the jumper across pins 1 and 2 of Jx03.
- For +10 dB of boost at 20 kHz, place the jumper across pins 2 and 3 of Jx03.
- To bypass the CD Horn Equalization, do not place a jumper in one position or the other.

		Header	Pins 1 & 2 	Pins 2 & 3 	None 
<b>Channel 1:</b>	Bypass low-pass	J101	X		
	Enable low-pass	J101		X	
	Bypass high-pass	J102	X		
	Enable high-pass	J102		X	
	Disable CD horn boost	J103			X
	CD horn boost, +6 dB @ 20 kHz	J103	X		
	CD horn boost, +10 dB @ 20 kHz	J103		X	
<b>Channel 2:</b>	Bypass low-pass	J201	X		
	Enable low-pass	J201		X	
	Bypass high-pass	J202	X		
	Enable high-pass	J202		X	
	Disable CD horn boost	J203			X
	CD horn boost, +6 dB @ 20 kHz	J203	X		
	CD horn boost, +10 dB @ 20 kHz	J203		X	

The table at left is a summary of the jumper settings for the MPC-XU.

## IV. Typical configurations

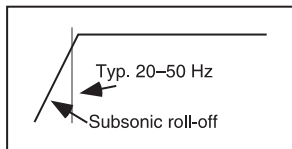

### Subsonic Filter (Infrasonic Filter)

**Applications:** Subsonic filters are commonly used in sound installations to filter out rumbles and other inaudible or unwanted low frequency signals and to protect speaker tuned vented speakers from damage due to excessive energy below the tuning frequency.

For a subsonic filter, determine the lowest useable frequency that the speaker can safely handle and set the *high-pass* filter to that frequency. Typical subsonic filters are set at 50 Hz, 40 Hz, 30 Hz or 20 Hz.

Program settings:

- 1 Set Jx01 to bypass the low-pass filter (if not using) by placing jumper across pins 1 and 2.
- 2 Set Jx02 to enable the high-pass filter by placing jumper across pins 2 and 3.
- 3 No jumper on Jx03.
- 4 Insert proper resistor network in RNx04 socket.

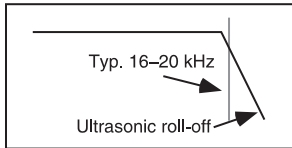

### Ultrasonic Filter

**Applications:** An ultrasonic filter is useful for minimizing RF interference, oscillations, leakage or aliasing from digital devices, or other signals that are too high in pitch to hear but may wreak havoc in an amplifier system.

Typical ultrasonic filters are set at 16 kHz or 20 kHz.

Program settings:

- 1 Set Jx01 to enable the low-pass filter by placing jumper across pins 2 and 3.
- 2 Set Jx02 to disable the high-pass filter (if not using) by placing jumper across pins 1 and 2.
- 3 No jumper on Jx03.
- 4 Insert proper resistor network in RNx02 socket.

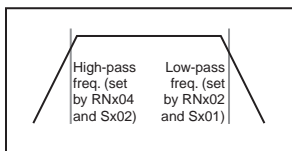

### Bandpass Filter

**Applications:** A bandpass filter is useful if the speaker system has a limited bandwidth.

Program settings:

- 1 Set Jx01 to enable the low-pass filter by placing jumper across pins 2 and 3.
- 2 Set Jx02 to enable the high-pass filter by placing jumper across pins 2 and 3.
- 3 No jumper on Jx03.
- 4 Insert proper resistor network corresponding to the lower limit of the desired passband in RNx04 socket.
- 5 Insert proper resistor network corresponding to the upper limit of the desired passband in RNx02 socket.

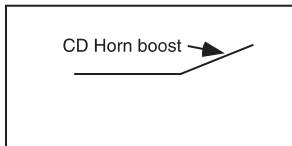

### CD Horn Equalization Filter

**Applications:** A constant directivity horn requires a 6 dB per octave boost at high frequencies to provide a flat frequency response. On the MPC-XU you must use the CD horn equalization in conjunction with the high-pass filter.

Program settings:

- 1 Set Jx01 to bypass the low-pass filter (if not using) by placing jumper across pins 1 and 2.
- 2 Set Jx02 to enable the high-pass filter by placing jumper across pins 2 and 3.
- 3 Set Jx03 to select the EQ curve you desire: across pins 1 and 2 to +6 dB at 20 kHz, or across pins 2 and 3 for +10 dB at 20 kHz.

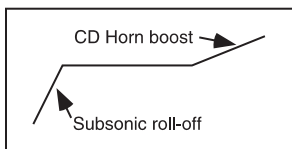

### Subsonic Filter with CD Horn EQ

**Applications:** This would be suitable only if the loudspeaker system uses a passive crossover.

Program settings: Use settings 1, 2 and 4 from the subsonic filter instructions and setting 3 from the CD horn equalization filter instructions above.

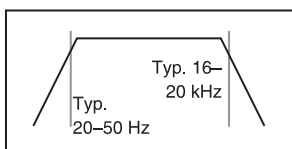

### Subsonic and Ultrasonic Filter

Program settings: Use settings 2, 3 and 4 from the subsonic filter instructions along with 2 and 3 from the ultrasonic filter instructions above.

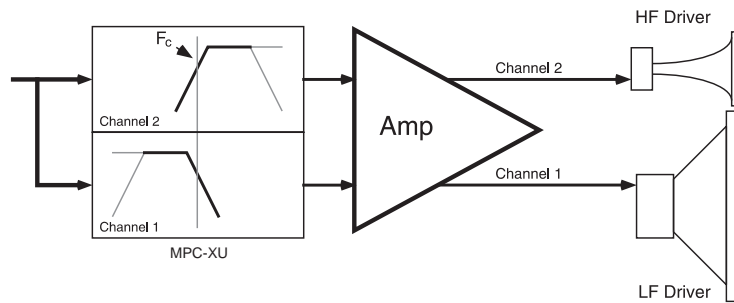

## 2-Way Active Crossover

This configuration routes the frequencies below a particular frequency to amplifier Channel 1, which will drive the low-frequency speaker(s), and the frequencies above to Channel 2, which will drive the high-frequency speaker(s). Using the MPC-XU as a crossover requires that you drive both amplifier inputs with the same full-band signal.

Program settings:

- 1 On the input module, set the amplifier mode to parallel. Alternately, you could use a Y-cable to provide the same signal to both channel inputs.

*Channel 1:*

- 2 Set J101 to enable the Channel 1's low-pass filter by placing jumper across pins 2 and 3.
- 3 No jumper on J103.
- 4 Insert a resistor network into RN102 that is appropriate to the desired crossover frequency.
- 5 Subsonic (infrasonic) filter—If you need subsonic (infrasonic) filtering, set J102 to enable the high-pass filter by placing jumper across pins 2 and 3, and insert a resistor network into RN104 corresponding to the roll-off frequency you desire. If you do not want subsonic (infrasonic) filtering, set J102 to disable the high-pass filter by placing jumper across pins 1 and 2.

*Channel 2:*

- 6 Set J202 to enable the Channel 2's high-pass filter by placing jumper across pins 2 and 3.
- 7 Insert a resistor network into RN204 that is appropriate to the desired crossover frequency.
- 8 *CD horn EQ*—If you need equalization for a constant-directivity horn, set a jumper on J203 for the amount of boost you need. If you do not want CD horn equalization, do not place any jumper on J203.
- 9 *Ultrasonic filtering*—If you need ultrasonic filtering, set a jumper on J201 across pins 2 and 3 to enable Channel 2's Low-pass filter and insert a resistor network into RN202 that corresponds to the desired roll-off frequency. If you do not want any ultrasonic filtering, set the jumper on J201 across pins 1 and 2 to bypass the low-pass filter.

## Multi-way Crossover System

The MPC-XU allows you to set up 3- and even 4-way systems. Of course, this also requires that you use more than one amplifier and more than one MPC-XU. You must feed each amplifier with the same full-range signal and use the MPC-XU to filter the signals in the individual channels. Each MPC-XU should be configured in the bandpass filter configuration as described above.

## V. Warranty & Contacting JBL

These products are designed and backed by JBL Professional, the world leader in sound reinforcement. For complete JBL warranty information, to order replacement parts or to ask for clarifications to this manual, contact JBL Professional:

*Within the United States:* Contact the Applications Dept, JBL Professional, PO Box 2200, 8500 Balboa Blvd, Northridge CA 91329 USA. In the USA you may call Monday through Friday 8:00 a.m. to 5:00 p.m. Pacific Coast Time: (818) 894-8850.

*In other areas throughout the world:* Contact the JBL Professional Distributor in your country.

A list of JBL Professional Distributors and U.S. Service Centers can be attained from the JBL Professional website: [www.jblpro.com](http://www.jblpro.com).

## Appendix

### Identifying resistor networks

Use this chart to identify the values of the resistor networks. See the tables on page 4 to find the correct values for the desired filter frequencies.

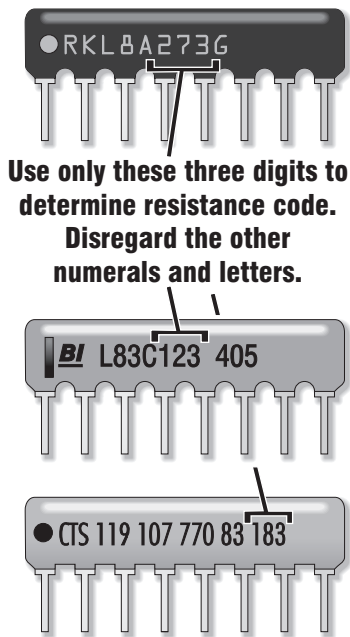

RESISTANCE	CODE
2.7K	272
3.9K	392
4.7K	472
5.6K	562
6.8K	682
8.2K	822
10K	103
12K	123
15K	153
18K	183
20K	203
22K	223
27K	273
33K	333
39K	393
47K	473
56K	563
68K	683



JBL Professional 8500 Balboa Boulevard, P.O. Box 2200 Northridge, California 91329 U.S.A.