

**JBL**

# AS1012-STD, Low Frequency AS1012-SP Loudspeaker System with Single 12-inch Transducer

## Architectural Series

### Key Features:

- ▶ VGC™ (Vented Gap Cooling™) low-frequency transducer with 100 mm (4 in) diameter edgewound voice coil and SFG™ magnet structure.
- ▶ Compact, light-weight trapezoidal enclosure for accurate cluster design.
- ▶ Multiple attachment points for efficient mounting.
- ▶ Options include: finish, color, input connections, and grilles.
- ▶ Usable response to 35 Hz.
- ▶ 95 dB 1 W/1 m sensitivity.
- ▶ 600 watt power rating.<sup>1</sup>

The JBL Architectural Series is a family of modular loudspeaker systems designed for fixed installation in applications ranging from speech reinforcement to large scale music reinforcement. All models in the series can be "customized" to meet specific designer needs in details of finish, mounting, and wiring, resulting in economy and time saving in the field.

The model AS1012 system is designed for smaller reinforcement applications and as an individual module in array design. The system has smooth power response and its axial response extends beyond 2 kHz. The 2206H transducer used in the AS1012 features JBL's unique VGC™ (Vented Gap Cooling™) technology for high power capacity and SFG™ (Symmetrical Field Geometry™), for extremely low distortion at high operating levels.

The enclosure is made of high quality birch plywood and is trapezoidal, with front-to-back tapering of 15° on each side. All joints are either dado or rabbet type, and the standard model comes with a textured black finish. The enclosure has twelve internal corner mounted steel plate attachment points which accept only 3/8 inch forged shoulder steel eyebolts for maximum safety.



### Specifications:

<b>SYSTEM:</b>	
Frequency Range ( - 10 dB):	35 Hz to 2.8 kHz
Frequency Response ( ± 3 dB):	40 Hz to 2.6 kHz
Input Power Rating <sup>1</sup> :	600 watts continuous pink noise
Rated Impedance:	8 ohms
Minimum Impedance:	6.9 ohms
Features:	VGC™ Cooling for high power handling and minimal power compression; SFG™ Geometry
Sensitivity <sup>1</sup> :	95 dB, 1 W at 1 m
Recommended Crossover:	High-pass: 30 Hz - 40 Hz (12 dB/oct) Low-pass: 800 Hz - 1.2 kHz (min. 12 dB/oct)
<b>COMPONENT:</b>	
Model:	2206H
Diameter:	300 mm (12 in)
For additional component data, refer to component specification sheets	
<b>ENCLOSURE:</b>	
Shape:	Trapezoidal, 15° taper per side
Material:	High grade birch plywood
Attachment:	12 points, accepts 3/8 in - 24 x 1 1/2 in forged shoulder steel eye bolts
Attachment Load Rating:	114 kg (250 lb) capacity per attachment point (5:1 safety factor, straight pull)
Finish:	Black textured paint
Grille:	Black, fire retardant on hardwood frame
Connector:	Terminal (barrier) strip
Dimensions (HxWxD):	737 mm x 603 mm x 438 mm (29 in x 23 3/4 in x 17 1/4 in)
Net Weight:	28.6 kg (63 lbs)
Shipping Weight:	35.4 kg (78 lbs)

<sup>1</sup>See individual driver specification sheets for rating methodology.

JBL continually engages in research related to product improvement. New materials, production methods, and design refinements are introduced into existing products without notice as a routine expression of that philosophy. For this reason, any current JBL product may differ in some respect from its published description, but will always equal or exceed the original design specifications unless otherwise stated.

## ► AS1012-STD, AS1012-SP

# Low Frequency Loudspeaker System with Single 12-inch Transducer

Optional finishes include a fiberglass covering for increased structural and surface durability, neutral paint which more easily facilitates repainting, and bare wood (premium Finnish birch) which can be stained to meet architectural requirements. Loudspeakers can also be ordered without attachment points.

For continued field support and future recognition of the loudspeaker's configuration, once an option (alternate finish, input connector, etc.) is incorporated into an Architectural Series product, the system is no longer a standard ("STD" suffix) model, but becomes a special ("SP" suffix) model. The list of available options is continually growing. Contact JBL Professional for current Option Code offerings, availability and pricing.

## Architects and Engineers Specifications:

The loudspeaker system shall consist of a 300 mm (12 in) low frequency transducer mounted in a direct radiator ported enclosure. The frame of the low frequency transducer shall be made of cast aluminum to avoid warping, and the voice coil shall be wound of aluminum ribbon wire with a diameter of 100 mm (4 in). The enclosure shall be constructed of high grade birch plywood and have a trapezoidal profile with front-to-back tapering of 15° per side for facility in arraying.

Performance specifications for a typical production unit shall be as follows: Under hemispherical free-field conditions, measured sensitivity shall be 95 dB at 1 W/1 m. Usable low frequency output shall extend down to 35 Hz (-10 dB) and be flat at 40 Hz ( $\pm 3$  dB). Rated impedance shall be 8 ohms. The transducer shall be capable of 600 watts, continuous pink noise input, with no greater than 3.9 dB of compression. The system shall be the JBL Architectural Series model AS1012. Other loudspeaker systems will be considered as equivalent provided that submitted data from a recognized independent test laboratory verify that the above performance specifications are met.

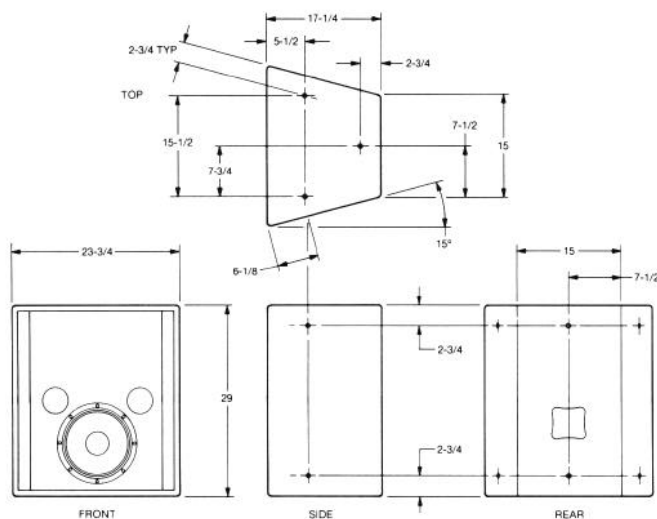

ALL DIMENSIONS ARE REF. ONLY  
NOTE: DIMENSIONS ARE IN INCHES

Frequency response and impedance AS1012-STD using 2.83 volts.

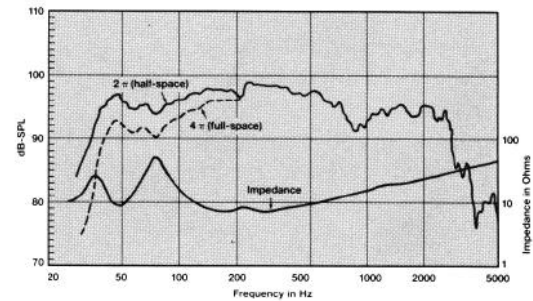

AS-1012-STD power compression at 1 watt, 10 watts, and 100 watts. 4π (full-space) measurement.

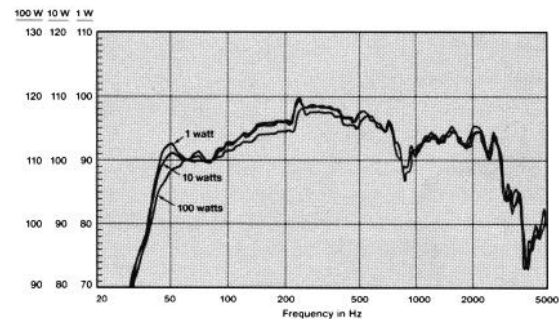

AS-1012-STD, fundamental, 2nd, and 3rd harmonic distortion (distortion raised 20 dB) at 60 watts input.

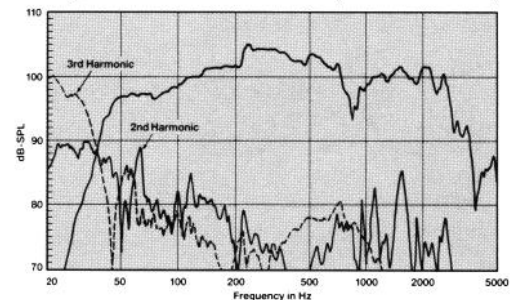

Directivity vs. frequency, AS-1012-STD.

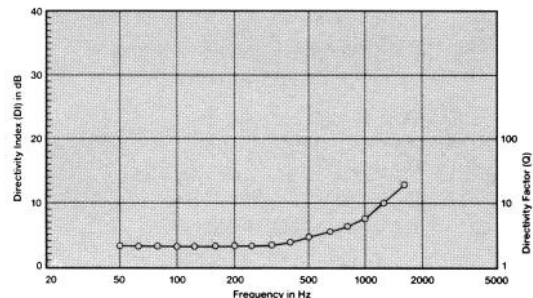

JBL Professional  
8500 Balboa Boulevard, P.O. Box 2200  
Northridge, California 91329 U.S.A.

■ A Harman International Company