

---

---

# 4847

---

---

LOW  
FREQUENCY  
SYSTEM

---

---

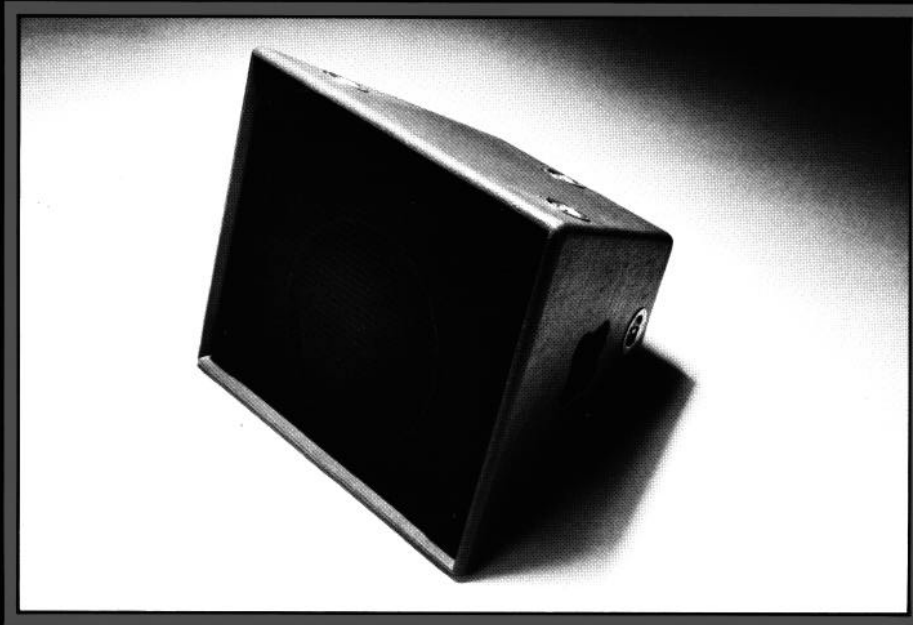

## FEATURES:

---

Smooth response to 1200 Hz with JBL 2225 15 in low frequency loudspeaker

Box tuning of 40 Hz

Road tested componentry and design configuration

Durable, fiberglass-reinforced exterior finish and rugged construction for touring sound applications

8 certified aircraft-style pan fitting hanging points, recessed and flush-mounted with cabinet surface

Top, bottom and sides taper inward at 15 degree angles, allowing cabinet groups to simulate single point source

Matches JBL 4860 family

---

The JBL 4847 is a compact low-frequency system designed to be used with the 4860 family of HF and HF/VHF speaker system components in the assembling of hanging arrays. The 4847 consists of a single 15 inch loudspeaker mounted in an optimally-designed, concert-proven package with integral hanging hardware fittings.

The 4847 enclosure uses a ported, direct-radiating design format to enable the placement of low frequency program material in 'down-throw' positions of hanging arrays. The cabinet's angled top, bottom and sides form a double wedge frustum, allowing the precise placement of the 4847 enclosure in a variety of positions within an array.

The 4847 is equipped with EP-8 input connectors. Two connectors are installed (one male, one female) to enable loop-through wiring for connecting additional 4847s or 4860 family systems. The 4847 comes wired, tested and ready for immediate use.

An accessory dolly, model 4870DL, is available to facilitate handling and cartage. The 4870DL also fits the 4860 family, 4845 and 4870 systems.

The Model 4847 is intended for use in the assembly of full-range multi-way hanging loudspeaker arrays. This precision-designed module is an integral component of the JBL Concert Series.

**ARCHITECTURAL SPECIFICATIONS:**

The low frequency loudspeaker system shall be of the vented direct radiator type, and shall meet the following unit performance criteria: Acoustic power output: 7 watts above 40 Hz. Frequency response: plus/minus 3 dB, 40 Hz to 1200 Hz. Power Capacity: 200 watts sine wave above 40 Hz. The loudspeaker system shall incorporate a driver with a peak linear displacement of 5mm, and a cabinet tuning frequency of 40 Hz with a total duct surface area of not less than 28 square inches.

The cabinet shall be constructed of void-free birch plywood, stiffened internally and coated with fiberglass reinforced plastic. All exposed corners shall be rounded for damage resistance. Aircraft-type hanging fixture attachment points shall be installed through the cabinet to internal steel reinforcement plates. Eight hanging points shall be provided. Each hanging point shall have a load rating of 2000 lbs. at 90 degrees to the fitting. Cabinet top, bottom and sides shall taper inward, front-to-back, at a 15 degree angle to facilitate cluster grouping.

The modular LF loudspeaker system shall be the JBL Concert Series model 4847.

**SPECIFICATIONS:**

Components:	1-JBL 2225H low frequency transducer		
SYSTEM SPECIFICATIONS:			
System Type:	Modular direct radiating low frequency loudspeaker system		
Frequency Range (-10 dB):	35 Hz to 3 kHz		
Frequency Response (± 3 dB):	40 Hz to 1200 Hz		
Nominal Impedance:	8 ohms		
Connectors:	ITT Cannon EP-8 type, one each male and female		
Dimensions:	63 cm (24¾ in) H 75 cm (29½ in) W 54 cm (21¼ in) D		
Weight:	43 kg (95 lbs)		
Finish:	Dark gray impregnated fiberglass-reinforced plastic, black nylon protective grill		
Quantity of Units:	One	Two	Four
Pressure Sensitivity (1 w, 1 m half-space):	97 dB	100 dB	103 dB
Nominal Efficiency (half-space reference):	3.5%	7.0%	14%
Power Capacity (continuous pgm) <sup>1</sup> :	400 w	800 w	1600 w
Power Output <sup>2</sup> :	7 w	28 w	112 w
Power Response (± 3 dB):	40-630 Hz	38-500 Hz	35-250 Hz
Maximum SPL at 1 m (half-space ref) <sup>2</sup> :	121 dB	127 dB	133 dB

<sup>1</sup> Continuous program power is defined as 3 dB greater than continuous sine wave power and is a conservative expression of the transducer's ability to handle typical speech and music program material.

<sup>2</sup> Usable acoustic power output at a given frequency in direct radiating systems is a function of piston surface area and linear axial displacement. Because music is periodic, acoustic power output is conservatively calculated as the product of reference efficiency and sine wave maximum input power. Peak values will be considerably higher, but subject to driver mechanical displacement limits at the lowest frequencies. Unlike products of manufacturers that rate maximum SPL on the basis of noise signals that result in ambiguous or dimensionless specifications, full acoustic power and maximum SPL are available at all frequencies within the stated power response envelope.

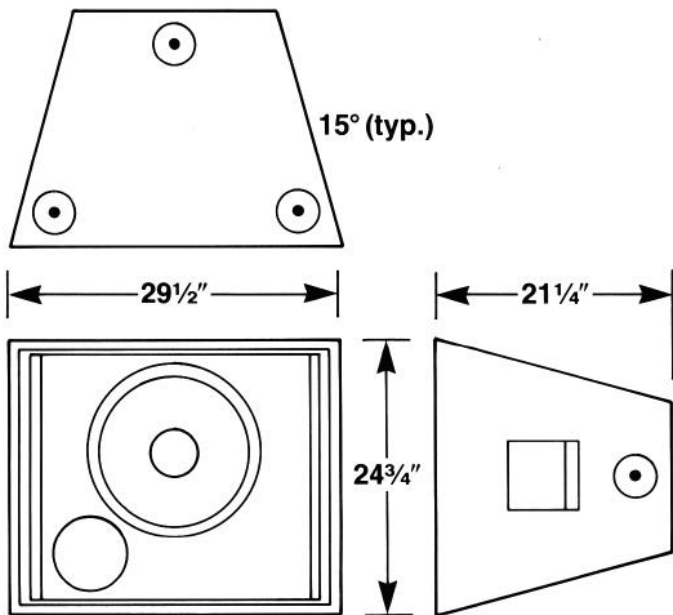

JBL continually engages in research related to product improvement. New materials, production methods, and design refinements are introduced into existing products without notice as a routine expression of that philosophy. For this reason, any current JBL product may differ in some respect from its published description but will always equal or exceed the original design specifications unless otherwise stated.

