

JBL

4645B Single 460 mm (18") Subwoofer System

Professional Series

Key Features:

- ▶ 2242H SVG® Super Vented Gap Cooled Driver
 - High Sensitivity
 - Low Power Compression
 - High Maximum SPL Capability
 - Extremely Low Second and Third Harmonic Distortion
 - Symmetrical Field Geometry (SFG®) Magnet Structure
 - Long Excursion Capability
- ▶ 800 Watts Continuous Pink Noise
1600 Watts Continuous Program
- ▶ Usable response to 18 Hz (-10 dB, no EQ) flat to 22 Hz (-3 dB) with External EQ
- ▶ THX® Approved

The JBL Model 4645B is a high quality subwoofer system, featuring an advanced technology 460 mm (18 in) low frequency transducer mounted in a direct radiator, bass-reflex enclosure for smooth response to the lowest audible frequencies. The 4645B is ideal for low-frequency augmentation of either analog or digital soundtracks in motion picture theaters and for general sound reinforcement applications.

Transducer:

The 2242H transducer utilizes the patented Vented Gap Cooling (VGC®) process, which pumps air through the magnetic gap and directly over and around the voice coil, providing immediate heat transfer and a reduction in operating temperature. This increases power handling while reducing power compression.

The 2242H utilizes a rugged 100 mm (4 in) diameter edge-wound aluminum voice coil and incorporates a large motor structure with a pole piece that extends both above and below the top plate to improve gap flux symmetry and increase thermal conductivity. This magnet structure and the use of a voice coil with one-third more exposed area



Specifications:

COMPONENTS:	JBL Model 2242H 460 mm (18 in) Low Frequency Transducer JBL Model 4518B Direct-Radiator Bass-Reflex Enclosure		
SYSTEM:			
Rated Impedance:	8 ohms		
Minimum Impedance:	8.0 ohms		
POWER HANDLING CAPABILITY:			
Continuous Pink Noise ¹ :	800 Watts		
Continuous Program ² :	1600 Watts		
Peak Power ³ :	3200 Watts		
OUTPUT CAPABILITY:			
Axial Sensitivity ⁴ :	50 Hz to 500 Hz: 99 dB @ 1W, 1m 40 Hz to 100 Hz: 97 dB @ 1W, 1m		
Maximum Power Compression ⁵ :	At -10 dB power (80 W): 0.6 dB At -3 dB power (400 W): 2.0 dB At rated power (800 W): 3.3 dB		
Half-Space Reference Efficiency ⁶ :	Single Module	Two Modules	Four Modules
Max. Continuous Acoustical Power Output:	4 %	8 %	16 %
Maximum Continuous SPL ⁷ :	16.8 W	67.2 W	268W
FREQUENCY RESPONSE ⁸ :	Lower Frequency limits (no EQ): -10 dB: 18 Hz -3 dB: 35 Hz Lower Frequency limits (with EQ): -10 dB: 20 Hz -3 dB: 22 Hz		
Recommended Crossover Frequencies:	High-Pass: 20 Hz. 24 dB/octave Low-Pass: 80 Hz to 120 Hz. 12 to 24 dB/octave		
Distortion ⁹ :	2nd Harmonic: < 0.6 % ; 3rd Harmonic: < 0.8 %		
System Polarity:	EIA Standard: Positive voltage to red terminal produces forward cone motion.		
Input Connectors:	Color-coded push terminals		
Net System Weight:	63 kg (138 lbs)		
Shipping Weight:	65 kg (151 lbs)		
ENCLOSURE:			
Materials and Finish:	19 mm (3/4 in) particle board with 25 mm (1 in) baffle and back panel. Extensive bracing on all panels.		
Enclosure Tuning Frequency:	25 Hz		
Net Internal Volume:	225 liters (8 cu. ft.)		
Dimensions:	1010 mm x 674 mm x 450 mm		
H x W x D	39 3/4 in x 26 1/2 in x 17 3/4 in		

See footnotes on back

▶ 4645B / Single 460 mm (18") Subwoofer System

than in former designs, provides the 2242H with very effective heat sinking, enabling the system to carry an 800 watt continuous RMS power rating.

The magnet structure and compliance allow for a long peak-to-peak excursions without damage to the speaker.

The pole piece incorporates a shorted copper ring which functions as a shorted secondary turn, with the voice coil acting as the primary winding. The benefits are a reduction of third harmonic distortion from magnetic flux modulation and a reduced inductive component of the voice coil impedance, for improved transient response. Symmetrical Field Geometry (SFG[®]) minimizes second harmonic distortion. The net effect is the virtual elimination of distortion.

Enclosure:

The enclosure is constructed of dense stock and is extensively braced on all panels. It has a net internal volume of 225 liters (8 cu. ft.) and is tuned to 25 Hz with large ports to minimize port compression and to reduce distortion due to turbulent air flow.

Frequency Response:

The 4645B features high sensitivity. It is intended for use as a subwoofer with a low-pass filter.

4645B DIMENSIONS

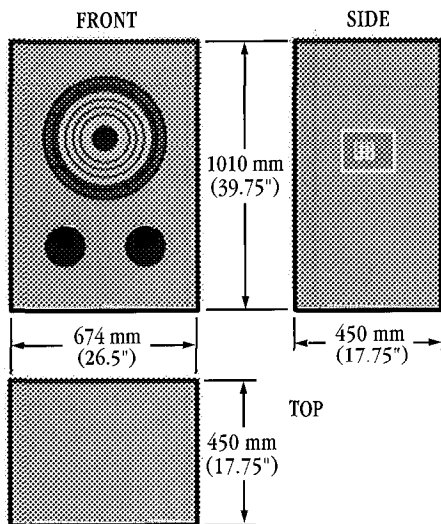

**Note: DRAWINGS NOT TO SCALE.
ALL DIMENSIONS ARE REFERENCE ONLY.
DIMENSIONS ARE IN MILLIMETERS (INCHES).

- 1 AES continuous pink noise (25 Hz - 250 Hz). 2 hours duration
- 2 Continuous program power is defined as 3 dB greater than AES continuous pink noise and is a conservative expression of the transducer's ability to handle normal music program material.
- 3 Peak power is defined as 6 dB greater than AES continuous pink noise, reflecting the 6 dB crest factor contained in the pink noise signal.
- 4 Averaged, half-space; Quarter-space (1 p, wall/floor junction placement) is 6 dB higher.
- 5 Power compression is the sensitivity loss at the specified power, measured from 50 Hz to 500 Hz, after a 5 minute AES standard (50 Hz to 500 Hz) pink noise signal at the specified power.
- 6 Based upon specified half-space 40 Hz to 100 Hz sensitivity; 50 Hz to 500 Hz reference efficiency is higher.
- 7 Per industry practice, maximum long-term SPL references half-space 1W/1 m sensitivity scaled by the long-term continuous power rating; Peak SPL is 6 dB greater.
- 8 Based upon specified sensitivity, 40 Hz to 100 Hz.
- 9 100 watt sine wave input, averaged from 40 Hz to 100 Hz.

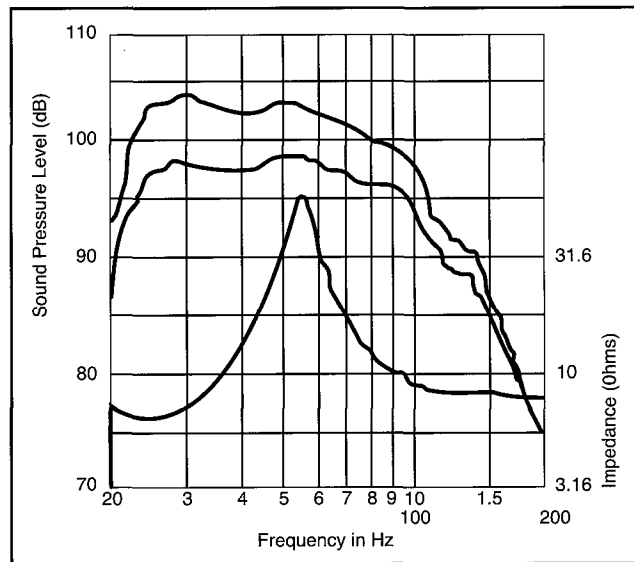

4645B frequency response, 1 watt at 1 meter, with equalization, 1π (top curve) and 2π (center curve) conditions.

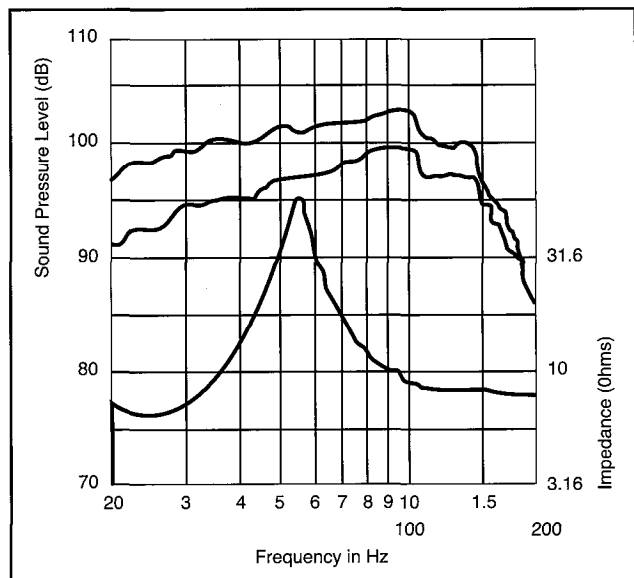

4645B frequency response, 1 watt at 1 meter, with 140 Hz, 24 dB/octave crossover (low-pass filter), no equalization, 1π (top curve) and 2x (center curve) conditions.

JBL continually engages in research related to product improvement. New materials, production methods and design refinements are introduced into existing products without notice as a routine expression of that philosophy. For this reason, any current JBL product may differ in some respect from its published description but will always equal or exceed the original design specifications unless otherwise stated.



JBL Professional
8500 Balboa Boulevard, P.O. Box 2200
Northridge, California 91329 USA

HA Harman International Company

SS 4645B
CRP 5M
10/96