

JBL Professional Series Model 4301B Broadcast Monitor

Accurate, smooth reproduction 45 to 15,000 Hz, ± 3 dB
88 dB SPL at 1 meter with a 1-watt input

Components: 200 mm (8 in) low frequency loudspeaker,
36 mm (1.4 in) high frequency direct radiator

Balance control located behind the removable grille

Oiled walnut enclosure



JBL

Model 4301B Broadcast Monitor

A compact monitor loudspeaker system designed specifically for broadcast applications, the 4301B delivers the wide band sound reproduction, accuracy and efficiency required by improved broadcast technology. Use of the 4301B is particularly relevant in light of the most recent broadcast developments, including TV/FM stereo simulcasting, AM stereo and multiplex television audio. Just as a video engineer wouldn't think of judging image quality on a household television receiver, an audio engineer shouldn't consider monitoring AM, FM, TV or film sound on anything less than a studio quality loudspeaker system.

A professional monitor, such as the 4301B, is of particular importance for monitoring the quality of the transmitted signal in order to detect and control spurious noise, i.e., turntable rumble, air conditioning and other acoustic interference picked up by open microphones, tape hiss or cue tone leakage. Such noise results in loss of broadcast power as well as signal degradation. Previously, monitoring these sounds would have been inconsequential since they exceeded the bandwidth or definition capabilities typical of audio transmission and reception. However, the competition for quality among broadcasters, enhanced by marked improvements in recorded program material, have resulted in a generation of equipment capable of transmitting high fidelity signals virtually equal to the program material. This, coupled with increased listener awareness of sound quality, has resulted in industry-wide improvement in broadcast technology, making accurate monitoring absolutely essential.

The 4301B shares its basic performance characteristics with all other JBL monitors — exceptional clarity, wide dynamic range, solid bass and open high frequency reproduction. The 4301B is efficient enough to produce a sound pressure level of 98 dB in a typical broadcast booth of 1.8 m x 3.0 m x 2.4 m (6 ft x 10 ft x 8 ft) with an amplifier delivering only 10 watts rms. The compact enclosure of the 4301B is designed to fit the smaller spaces typical of broadcast control booths, production studios or mobile recording, broadcast and film editing facilities.

Low Frequency Loudspeaker

The 4301B utilizes a low frequency loudspeaker specifically engineered for a compact enclosure without the compromises usually associated with smaller drivers. The 200 mm (8 in) loudspeaker exhibits unusually smooth frequency response, wide dynamic range, superior transient reproduction and low distortion for a unit of compact size. It features a precision die-cast aluminum frame for structural integrity under the most severe operating conditions. The 50 mm (2 in) diameter copper voice coil is suspended in a magnetic

field having a flux density of 0.85 tesla. The magnetic field is generated by a 1.28 kg (3 lb) low-loss magnetic assembly. Mass and compliance of the integrally stiffened cone have been carefully selected to optimize low frequency bandwidth and definition while reducing distortion. As with all JBL loudspeakers, this unit provides maximum power handling capacity and efficiency consistent with the bandwidth expected of the device.

High Frequency Direct Radiator

The open, crisp treble performance of the 4301B is the product of a 36 mm (1.4 in) direct radiator designed for clarity, smoothness of response and power handling capacity. The 16 mm ($\frac{5}{8}$ in) copper voice coil is large in relation to cone size for efficiency and transient reproduction with definition and accuracy, yet the diameter of the cone and center dome has been kept small to obtain wide dispersion. The magnetic assembly weighs 0.74 kg (1 $\frac{1}{2}$ lb) and generates a flux density of 1.5 tesla.

Frequency Dividing Network

Smooth control of the component loudspeakers is achieved by a frequency dividing network engineered and tested to complement the electrical and acoustical characteristics of the system. The dividing network is fitted with a continuously variable control that permits adjusting the relative level of the high frequency direct radiator to suit listening preferences and room conditions. The control does not affect the crossover frequency, nor does it limit the upper frequency response of the loudspeaker system.

Enclosure

Size and configuration of the 4301B enclosure have been carefully matched to the acoustic characteristics of the component loudspeakers as well as the intended use of the complete system. To achieve maximum strength and resistance to vibration, all enclosure joints are hand fitted; all panels are constructed of 19 mm ($\frac{3}{4}$ in) dense compressed stock. This material, also known as particle board, is preferred to solid wood for its superior acoustical properties. Acoustic damping material is applied to the interior surfaces of the side and back panels to attenuate standing waves within the enclosure. A ducted port extending through the baffle panel provides proper acoustical loading of the low frequency loudspeaker. All components mount directly to the baffle panel and are removable from the front of the enclosure. The four side panels are veneered with solid American black walnut, hand rubbed to a rich, lustrous finish enhancing the natural beauty of individual grain structure and color.

Test Conditions

The accompanying graph and specifications were compiled from measurements made under carefully controlled conditions. The loudspeaker system was mounted flush in the center of a large, flat baffle in a non-reverberant environment. Laboratory-standard condenser microphones were suspended in a spherical pattern around the acoustic center of the system, sufficiently distant to be out of the near field, so that data taken would reflect the total output of the combined transducers. In keeping with accepted laboratory practice, all equipment was checked and calibrated before tests were conducted.

Bandwidth On-Axis

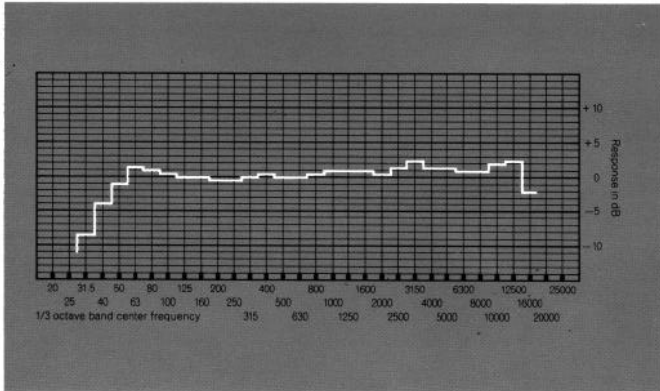

Frequency response of the 4301B taken with 1/3-octave band pink noise. Measured response contour of a typical system averaged through an inclusive arc of 30° in the vertical and horizontal planes does not deviate more than 3 dB from the above curve.



Loudspeaker system components of the 4301B Broadcast Monitor

Specifications

| | |
|--|---|
| Power Capacity | 15 W continuous sine wave |
| Nominal Impedance | 8 ohms |
| Power Output ¹ | 88 dB SPL measured at 3 m (10 ft) in a room volume of 57 m ³ (2000 ft ³) with an average absorption of 18.6 m ² (200 ft ²) at ½ rated power input (-3 dB) |
| Frequency Response | |
| Sine Wave, On-Axis | 45 to 15,000 Hz, ±3 dB |
| ½-Octave Band (400 Hz Reference) | -3 dB at 50 Hz 0 dB at 1200 Hz +2 dB at 12 kHz |
| Polar Response | No less than -6 dB at 90° horizontal and vertical to 10 kHz |
| Sensitivity | 88 dB SPL measured at 1 metre (3.3 ft) with a 1-watt input averaged from 500 to 2500 Hz |
| Distortion | |
| ½ Power, 87 dB SPL/3 m (10 ft), Single Frequency | 0.5% or less third harmonic generation from 100 to 15,000 Hz |
| Crossover Frequency | 2500 Hz |
| Finish | Oiled walnut |
| Grille | Dark blue fabric |
| Enclosure Volume | 28 L 1 ft ³ |
| Enclosure Dimensions | 483 mm x 292 mm x 306 mm deep (19 in x 11½ in x 12½ in deep) |
| Net Weight | 12 kg 26 lb |
| Shipping Weight | 13.6 kg 30 lb |

1. Power output measured with a B&K Impulse Precision Sound Level Meter.

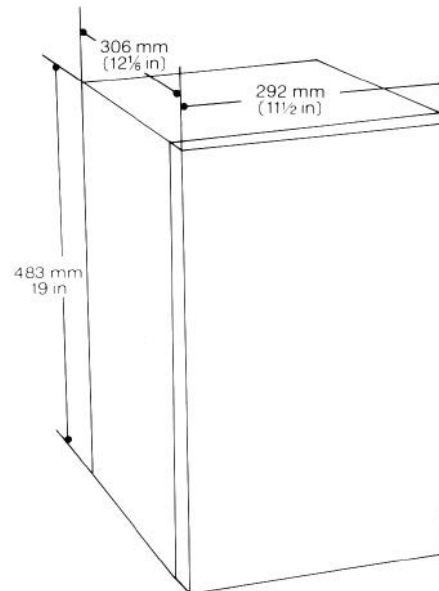

JBL continually engages in research related to product improvement. New materials, production methods and design refinements are introduced into existing products without notice as a routine expression of that philosophy. For this reason, any current JBL product may differ in some respect from its published description but will always equal or exceed the original design specifications unless otherwise stated.