

SP225-6 Two-Way Full Range Loudspeaker System For Permanent Installation

Sound Power Series

Key Features:

- ▶ VGC (Vented Gap Cooled™) LF transducers
- ▶ Opt Apt HF horn with 1.5" exit compression driver
- ▶ Trapezoidal enclosure for easy cluster arrangements
- ▶ DuraFlex finish, tough, weather resistant and paintable
- ▶ Internal tamper resistant Bi-Amped/Passive selector
- ▶ 12 Suspension points (M10 Thread)
- ▶ Advanced Network Topologies for smooth power response and stable amplifier loading

The model SP225-6 is a true, full range system that provides unprecedented bandwidth and maximum SPL in a single system package. With nominal 60° coverage pattern, systems can be splayed together for additional coverage and/or SPL requirements. Two powerful 15" VGC (Vented Gap Cooled™) LF transducers provide powerful transient bass. The proven Optimized Aperture™ HF horn coupled to a 2447J, 1.5" exit compression driver delivers a precise, clear and controlled high frequency response.

The SP225-6 is equipped with a passive crossover that can be switched to bi-amplified use via an easily accessible internal tamper resistant selector. Bi-amplified mode, utilizing the DSC260 digital controller for crossover, signal alignment, and equalization functions, provides optimum system performance.

The SP225-6 is part of the JBL Sound Power Series, a family of modular loudspeaker systems designed for fixed installation applications ranging from speech reinforcement to large scale music productions. All models are fitted with suspension points that accept M10 threads. The enclosures are finished with a hard wearing, weather resistant, textured finish DuraFlex. Premium 13 ply wood and an 18 gauge steel, foam-backed grille enable Sound Power systems to comply with environment test specifications.

Components:

The SP225-6 utilizes one of JBL's finest cone transducers, the 2226H. The 15" 2226H are part of JBL's family of Vented Gap Cooled woofers and carries an AES power rating of 1200 watts with minimal power compression. The cone has been treated for weather resistance.

The 38mm (1.5 in) exit 2447J large format compression driver is coupled to an Optimized Aperture Bi-Radial® horn providing smooth even coverage. The Optimized Aperture horn provides lower throat distortion than its earlier predecessors while extending frequency response to nearly 20 kHz.



Specifications:

System:

Freq. Range (-10 dB):	33 Hz - 20 kHz
Freq. Response (-3 dB):	42 Hz - 18 kHz
Horz. Coverage Angle (-6 dB):	70° averaged 500 Hz to 16 kHz
Vert. Coverage Angle (-6 dB):	45° averaged 500 Hz to 16 kHz
Directivity Factor (Q):	15.8 averaged 500 Hz to 16 kHz
Directivity Index (DI):	12.0 averaged 500 Hz to 16 kHz
System Sensitivity ¹ :	100 dB, 1 W @ 1 m (3.3 ft)
Rated Maximum SPL:	136 dB, @ 1 m (3.3 ft)
System Nominal Impedance:	4 Ohms
System Input Power Rating ² :	1200 W, IEC; 4800 W Peak
Recommended Amplifier ³ :	1600 W
Recommended Controller:	DSC260
Passive Crossover:	1.2 kHz

Transducers:

Low Frequency:	2 x 2226H, 380 mm (15 in) dia., 100 mm (4 in) edgewound ribbon voice coil
Nominal Impedance:	4 Ohms
Input Power Rating:	1200 W, AES; 4800 W Peak
Sensitivity ¹ :	100 dB, 1 W, @ 1 m (3.3 ft)
Calculated Maximum SPL:	137 dB, @ 1 m (3.3 ft)
Recommended Amplifier ³ :	1600 W
High Frequency:	2447J; 100 mm (4") diaphragm and voice coil dia., 76 mm (1.5") throat dia.
Nominal Impedance:	16 Ohms
Input Power Rating:	75 W, AES; 300 W Peak
Sensitivity ¹ :	114 dB, 1 W, @ 1 m (3.3 ft)
Calculated Maximum SPL:	139 dB, @ 1 m (3.3 ft)
Recommended Amplifier ³ :	200 W

Physical:

Enclosure:	Trapezoidal, 22.5° side angles, birch plywood
Environmental Specifications:	Mil-Std 810, IPX4 per IEC 529
Suspension Attachment:	12 points; accepts M10 threaded hardware
Finish:	Black DuraFlex coating
Grille:	Black powder coated zinc treated 18 gauge perforated steel grille with foam backing
Input Connectors:	2 x NL4 Neutrik Speakon connectors
Dimensions:	1151 mm x 451 mm x 451 mm (45.30 in x 17.75 in x 17.75 in)
Net Weight:	53.5 kg (118 lbs.)

¹Measured on axis in the far field with 1 watt (2.0 V RMS, 4 ohms) input and referenced to 1 meter distance using the inverse square law. Listed sound pressure represents an average from 300 Hz to 16 kHz.

²IEC Spectrum for 2 hours with +6 dB crest factor.

³Recommended Amplifier is a power capability value that should be taken as a guide.

JBL continually engages in research related to product improvement. New materials, production methods, and design refinements are introduced into existing products without notice as a routine expression of that philosophy. For this reason, any current JBL product may differ in some respect from its published description, but will always equal or exceed the original design specifications unless otherwise stated.

SP225-6 2 way System

Frequency Response is measured on-axis at a distance referred to 1 m at 1 watt (2.0 Vrms) input, shown as a half-space (2π) environment.

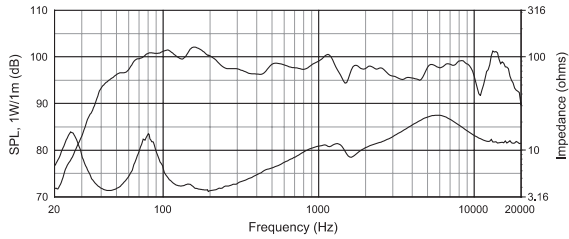

Horizontal Off Axis Frequency Response

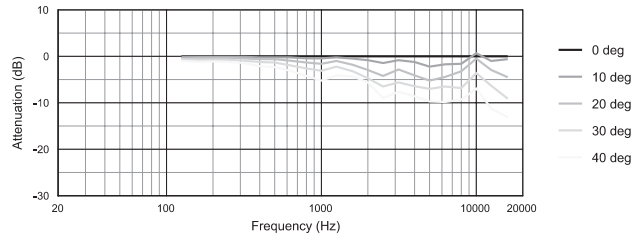

Beamwidth vs. Frequency

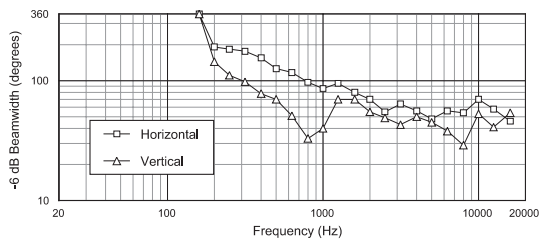

Vertical Off Axis Frequency Response (up)

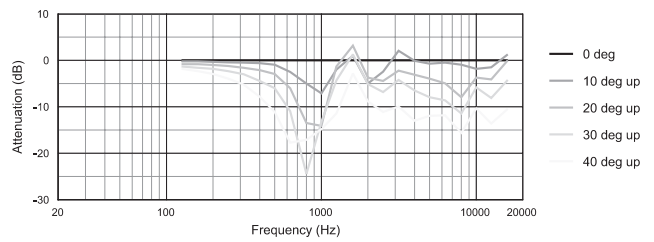

Directivity vs. Frequency

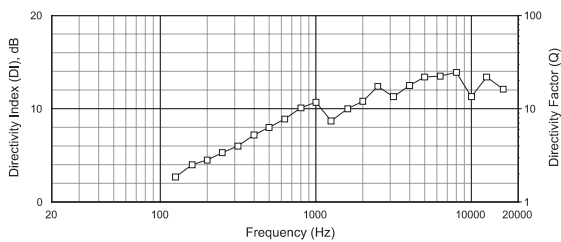

Vertical Off Axis Frequency Response (down)

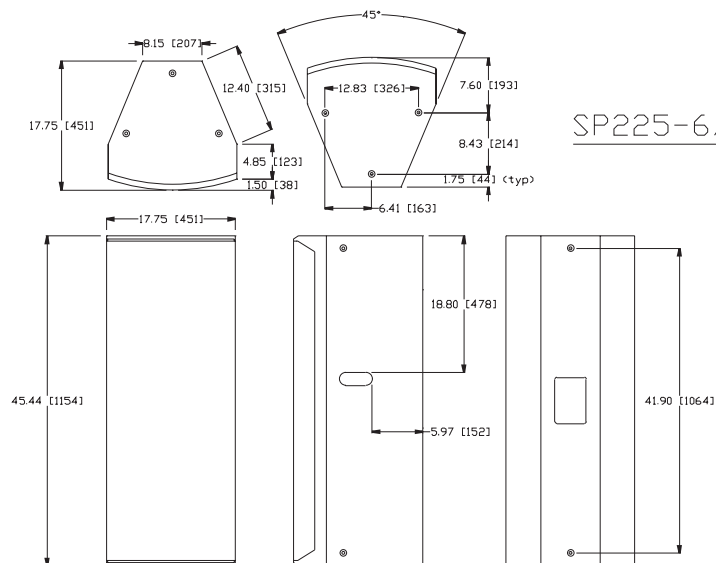
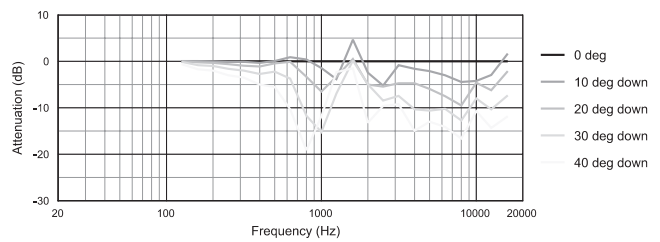

SP225-6/9

Horizontal 1/3 Octave Polars

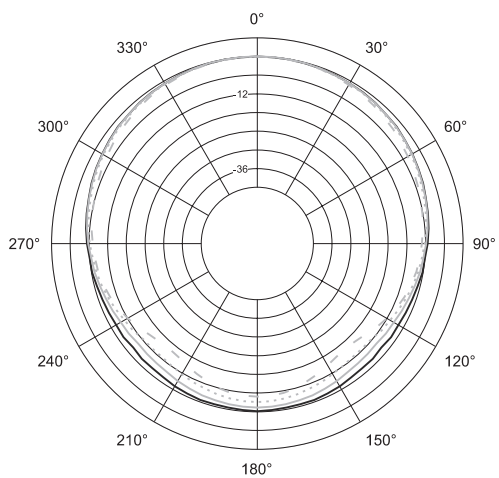

- 200Hz
- 250Hz
- ... 315Hz
- - 400Hz

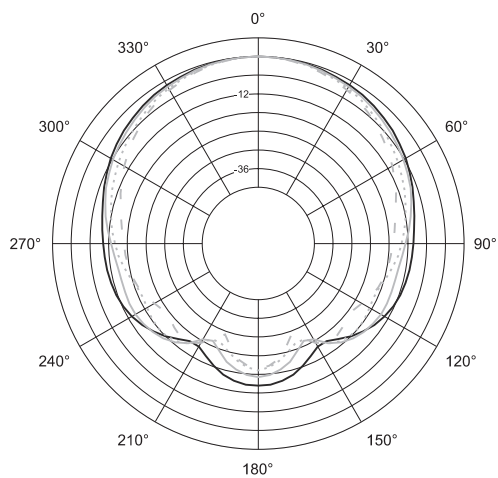

- 500Hz
- 630Hz
- ... 800Hz
- - 1kHz

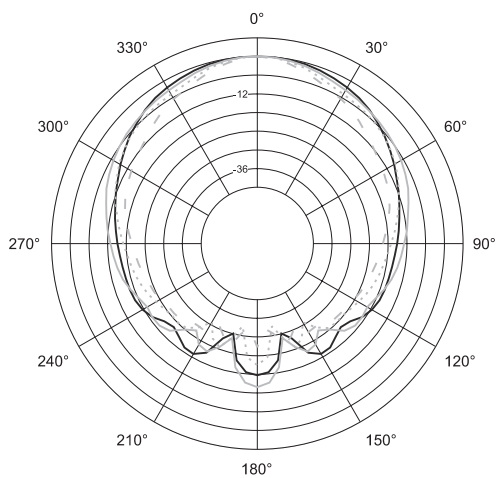

- 1.25kHz
- 1.6kHz
- ... 2kHz
- - 2.5kHz

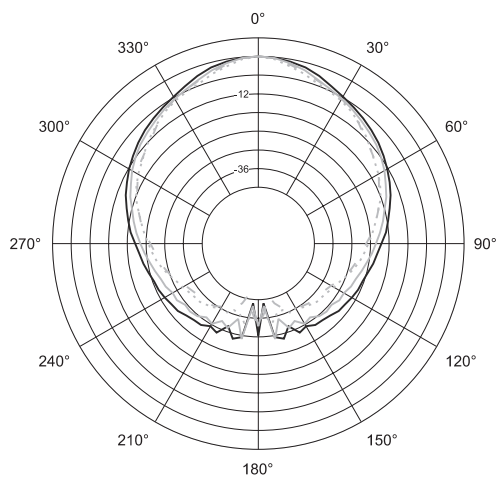

- 3.15kHz
- 4kHz
- ... 5kHz
- - 6.3kHz

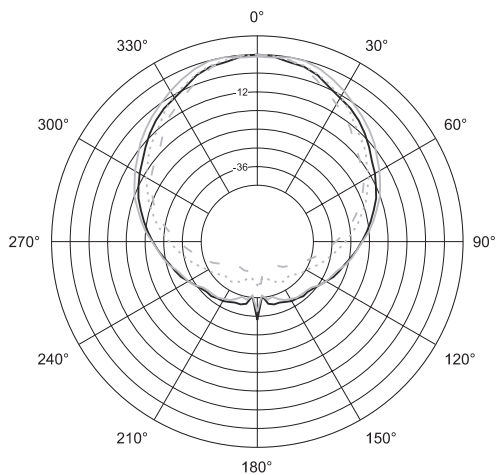

- 8kHz
- 10kHz
- ... 12.5kHz
- - 16kHz

▶ SP225-6 2 way System

Vertical 1/3 Octave Polars

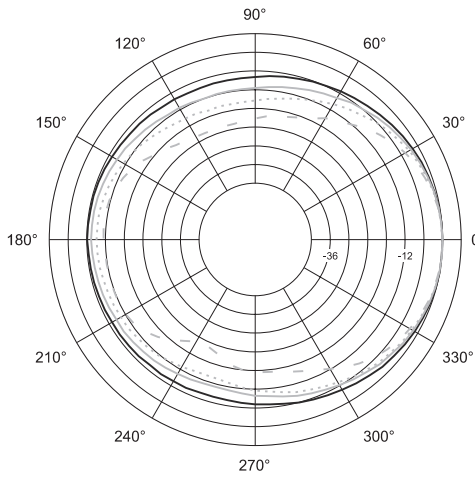

- 200Hz
- 250Hz
- 315Hz
- - - 400Hz

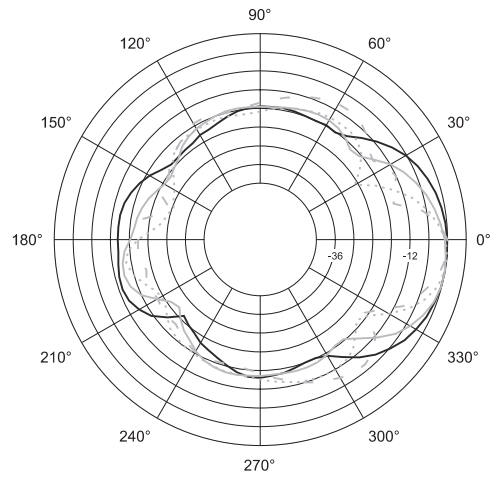

- 500Hz
- 630Hz
- 800Hz
- - - 1kHz

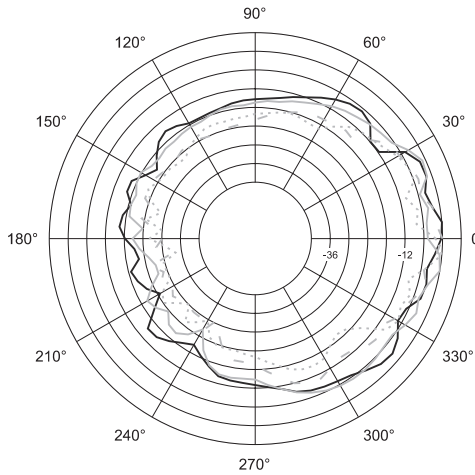

- 1.25kHz
- 1.6kHz
- 2kHz
- - - 2.5kHz

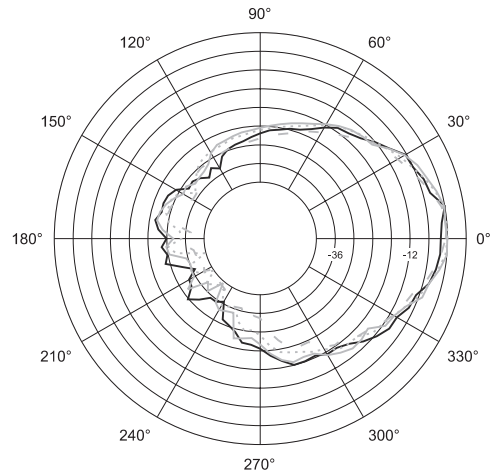

- 3.15kHz
- 4kHz
- 5kHz
- - - 6.3kHz

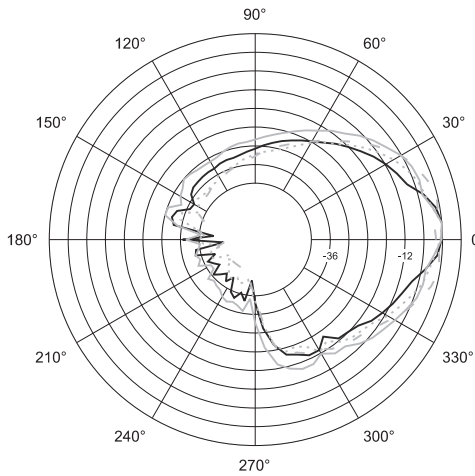

- 8kHz
- 10kHz
- 12.5kHz
- - - 16kHz



JBL Professional
 8500 Balboa Boulevard, P.O. Box 2200
 Northridge, California 91329 U.S.A.

■ A Harman International Company