



3632 3632-T

Three-Way Bi-Amplified ScreenArray™ Cinema Loudspeaker System Three-Way Tri-Amplified ScreenArray™ Cinema Loudspeaker System

Application:

For critical film sound reproduction in small to medium cinemas and studio production and post-production environments.

Key Features:

- ▶ Three-way ScreenArray™ design for maximum output, optimal coverage, and minimum distortion
- ▶ Available for Bi-amplified operation (Model 3632) or Tri-amplified operation (Model 3632-T)
- ▶ Approved for THX® certified applications (3632-T)
- ▶ Ships fully assembled
- ▶ Second Generation Optimized Aperture Waveguide technology for ultra-low distortion, and extremely uniform frequency response
- ▶ SSC™ Screen Spreading Compensation
- ▶ Focused Coverage Technology™
- ▶ Flat-front waveguide design for easy baffle wall installation
- ▶ Shallow profile for minimum behind screen depth requirements

Today's Cinema patron demands perfect coverage in every seat of the auditorium, wide dynamic range and extended bandwidth, as well as inaudible levels of distortion. Digital soundtracks have the potential to push the traditional two-way screen channel speaker system beyond intended performance limits. This dictates the need for a new standard of loudspeaker performance for today's premier cinemas.

The 3632 ScreenArray features true three-way system design enhanced by advanced engineering. JBL Professional's best technical innovations are integrated in a system design that provides superior coverage, maximum power handling, and uniform acoustic power output, along with extremely low distortion. The ScreenArray design provides ideal power response and directivity control with seamless transitions between acoustic sections. The 3632 is available for either bi-amplified or for tri-amplified operation.



Specifications:

System: [3632-T Specifications in Brackets]	
Frequency Range:	30 Hz - 20 kHz
Frequency Response (±3 dB):	40 Hz - 16 kHz
System Sensitivity:	104 dB, 2.83V @ 1m (3.3 ft)
Rated Maximum SPL:	126 dB @ 1m (3.3 ft), 132 dB peak
System Input Power Rating:	LF: 500 watts, M/HF: 150 watts [HF: 50 watts]
Hor. Coverage Angle (-6 dB):	90°
Vert. Coverage Angle (-6 dB):	20° up, 30° down
Directivity Factor (Q):	10.0
Directivity Index (DI):	10 dB
Crossover Frequencies:	350 Hz, [1.2 kHz]
Dimensions (HxWxD):	1937 mm x 762 mm x 450 mm (76.3 in x 30 in x 17.75 in)
Net Weight:	97.7 kg (215 lbs)
Shipping Weight:	112.5 kg (248 lbs)
Component Elements:	
Model 3639 Low Frequency: [4632-T uses 4639 Low Frequency]	2 x M115H-8A; 380 mm (15 in) dia., 64 mm (2.5 in) edgewound ribbon voice coil transducers mounted in 4509 LF enclosure
Nominal Impedance:	4 ohms
Input Power Rating:	500 watts AES; 600 watts recommended amplifier
Sensitivity:	104 dB SPL, 2.83V @ 1 m (3.3 ft)
Input Connectors:	Push terminal binding posts
Dimensions (HxWxD):	883 mm x 762 mm x 450 mm (34.75 in. x 30 in. x 17.75 in.)
Net Weight:	57.7 kg (127 lbs)
Shipping Weight:	64.5 kg (142 lbs)
Model 3632-M/HF	Nominal Impedance: 8 ohms [MF: 12 ohms, HF: 8 ohms]
Input Power Rating:	150 watts AES; 300 watts recommended amplifier [MF: 150 watts AES; 300 watts recommended amplifier] [HF: 50 watts AES; 200 watts recommended amplifier]
Sensitivity:	104 dB SPL, 2.83V @ 1 m (3.3 ft) [MF: 108 dB SPL, 2.83V @ 1 m (3.3 ft)] [HF: 114 dB SPL, 2.83V @ 1 m (3.3 ft)]
Input Connectors:	Screw terminal barrier strip
Mid Frequency:	2 x 165H; 165 mm (6.5 in) dia., 38 mm (1.5 in) voice coil
High Frequency:	2418H-1; 44 mm (1.75 in) titanium diaphragm and voice coil dia., 25 mm (1 in) exit diameter
Dimensions (HxWxD):	1054 mm x 762 mm x 450 mm (41.5 in. x 30 in. x 17.75 in.)
Net Weight:	40.0 kg (88 lbs)
Shipping Weight:	48.1 kg (106 lbs)

JBL continually engages in research related to product improvement. Some materials, production methods and design refinements are introduced into existing products without notice as a routine expression of that philosophy. For this reason, any current JBL product may differ in some respect from its published description, but will always equal or exceed the original design specifications unless otherwise stated.

¹ See 4632 specification sheet for 4639 specifications.

▶ 3632/3632-T ScreenArray™ Three-Way Cinema Loudspeaker Systems

The 3632 ScreenArray represents the embodiment of JBL's continued commitment to the movie cinema industry. As such the 3632 incorporates the latest advances in JBL's research into high performance transducer, waveguide, and crossover designs. Incorporating the performance benefits of SCC™ (Screen Spreading Compensation) and Filtered Array Technology™, the 3632 provides smooth and uniform timbral balance consistent with current industry listening standards.

Screen Spreading Compensation corrects for the high frequency dispersion of a perforated movie screen.

Focused Coverage Technology provides an asymmetrical coverage pattern tilted 10° downward from horizontal to provide uniform coverage in every seat in either traditional or stadium seating auditoriums. In its bi-amplified configuration, a passive signal processing network maintains optimal vertical dispersion of the midrange and high frequency elements.

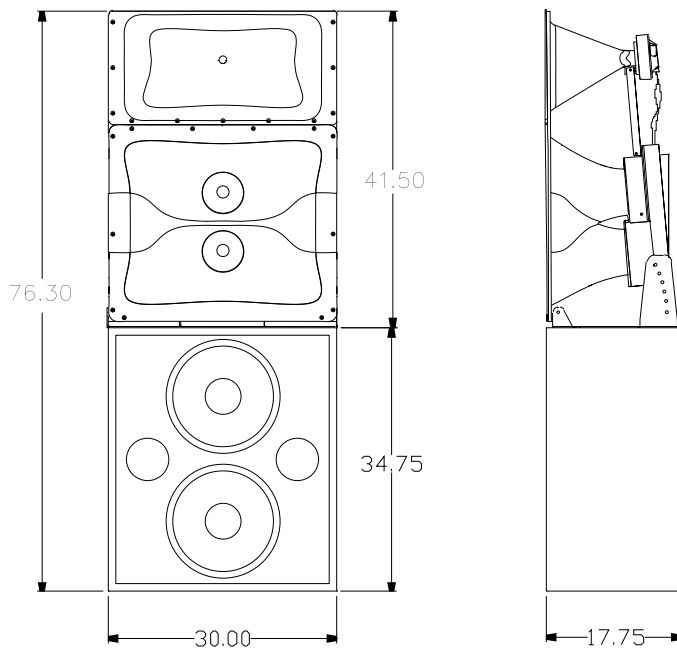

Frequency Response in half-space (2π)

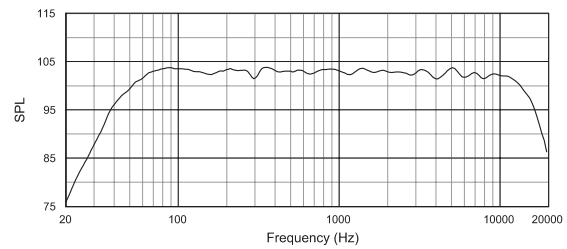

Bandwidth vs. Frequency

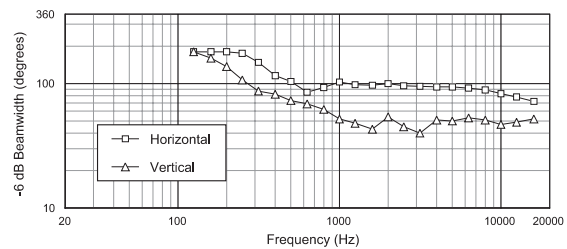

Directivity Index and Directivity Factor

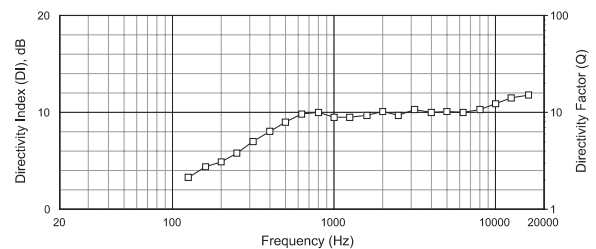

JBL Professional
8500 Balboa Boulevard, P.O. Box 2200
Northridge, California 91329 U.S.A.

■ A Harman International Company

SS 3632/3632-T
CRP 10M
10/00