

Application

- ▶ For critical film sound reproduction in large cinemas

Key Features:

- ▶ Three-way system design for maximum output with minimum distortion
- ▶ Optimized Aperture Bi-Radial® horn and driver technology for ultra-low distortion
- ▶ Midrange pattern control for increased direct to reverberant ratio
- ▶ Four 380 mm (15") Vented Gap Cooled (VGC™) LF transducers in DiamondQuad™ LF driver array
- ▶ Flat-front design for easy baffle wall installation
- ▶ Fully adjustable horn bracket for aiming in any direction

Digital soundtracks on today's feature films have the potential of pushing traditional two-way speaker system designs beyond their performance limits. Requirements for wide dynamic range, high power handling and low distortion dictate the need for a new standard of performance for today's premier cinemas.

The 5000 Series Cinema Systems feature true three-way system design, with each section optimized for its specific bandpass region. All systems feature the best of JBL transducer and horn technology to produce a system design with maximum power handling capability and acoustic power output, with extremely low distortion. The system has been designed with particular attention to power response and directivity control, allowing seamless transitions between the three acoustic sections and smooth timbral character, consistent with current industry listening standards. The 5674 is JBL Professional's most advanced cinema system for behind screen applications.



Specifications:

	Frequency Range (-10 dB):	35 Hz - 16 kHz
	Frequency Response (± 3 dB):	45 Hz - 12.5 kHz
	Hor. Coverage Angle (-6 dB):	80°, averaged 300 Hz to 16 kHz
	Vert. Coverage Angle (-6 dB):	45°, averaged 300 Hz to 16 kHz
	Directivity Factor (Q):	10.4
	Directivity Index (DI):	11
	Maximum peak output (1 m):	LF: 142.8 dB, MF: 140 dB, HF: 136.8 dB
	Recommended Crossover Freq.	LF/MF: 297 Hz, MF/HF: 2.5 kHz
	Recommended Controller:	JBL DSC family of digital controllers; tunings available in memory
	Dimensions (HxWxD):	2895.6 mm x 1118 mm x 812.8 mm (114 in. x 44 in. x 34 in.)
	Net Weight:	171.69 kg (378.5 lbs.)
	Shipping Weight:	190.5 kg (420 lbs.)
	Transducers:	
Model 5644	Low Frequency:	Four 2226H 380 mm (15 in.) dia., 100 mm (4 in.) edgewound ribbon voice coil mounted in 5504 LF enclosure in DiamondQuad driver array
	Nominal impedance:	Each pair in parallel; 4 ohm loads per driver pair
	Input Power Rating:	2400 W, AES; two channels of 1200 W Recommended Amplifier per driver pair
	Sensitivity:	103 dB, 1 W @ 1 m (3.3 ft.)
	Input Connectors:	Barrier Strip
	Dimensions (HxWxD):	1118 mm x 1118 mm x 623 mm (44 in. x 44 in. x 24.5 in.)
	Net Weight:	136 kg (300 lbs.)
	Shipping Weight:	145.2 kg (320 lbs.)
Model 5674-19/HF	Mid Frequency:	2392 midrange horn 2490H midrange driver; 100 mm (4 in.) edgewound ribbon voice coil
	Nominal impedance:	8 Ohms
	Input Power Rating:	100 W, AES; 300 W Recommended Amplifier
	Sensitivity:	114 dB, 1 W @ 1 m (3.3 ft.)
	Net Weight:	28.35 kg (62.5 lbs.)
	High Frequency:	2352 midrange horn 2451H midrange driver; 100 mm (4 in.) edgewound ribbon voice coil
	Nominal impedance:	8 Ohms
	Input Power Rating:	75 W, AES; 200 W Recommended Amplifier
	Sensitivity:	112 dB, 1 W @ 1 m (3.3 ft.)
	Net Weight:	7.26 kg (16 lbs.)
	Mounting Accessories:	HF horn baffle board and mounting frame which couples MF and HF; mounts to LF enclosure for aiming/tilting

▶ 5674 Three-Way Screen Channel System

The 5674 is intended for tri-amplified use, utilizing JBL's DSC family of digital controllers. Crossover, signal alignment, and equalization can be accomplished using three channels of digital signal control, using factory pre-set tunings, for optimum performance from the 5674.

System Components

The 5674 consists of three sections: high frequency horn/driver, midrange horn/driver, and low frequency enclosure. The JBL 2352 Optimized Aperture Bi-Radial[®] horn with the JBL 2451H compression driver provides exceptionally low-distortion high frequency output due to JBL's new "rapid flare" horn and driver design. The 2451H is a 1.5 inch exit driver with a neodymium magnet structure and pure titanium 100 mm diaphragm. The mid range section features JBL's 2392 Optimized Aperture Bi-Radial horn, coupled with the JBL 2490H 3 inch-exit compression driver, designed specifically for the critical midrange region. The low frequency section of the 5674 uses a new-design 23.5 cubic foot (total net internal volume) enclosure with four JBL 2226H VGC drivers in a unique DiamondQuad[™] array. The DiamondQuad array orientation allows the four drivers to create maximum output, while minimizing destructive interference effects caused by the use of multiple drivers operating in the same bandpass region.

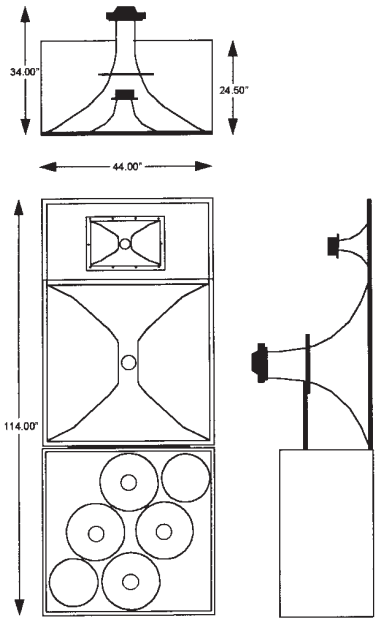

Axial Frequency Response, 1/3 octave resolution

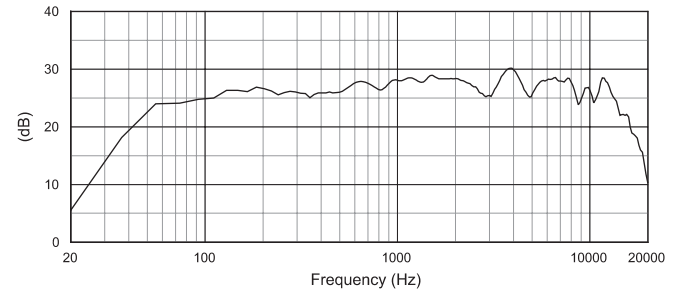

Directivity Index and Q

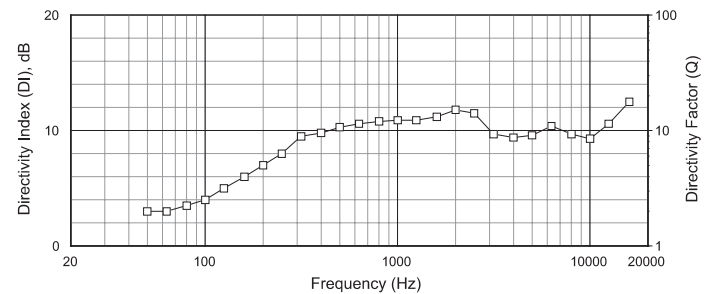

Distortion, 10 watts at 4 meters, 2nd and 3rd harmonics, MF and HF sections only.

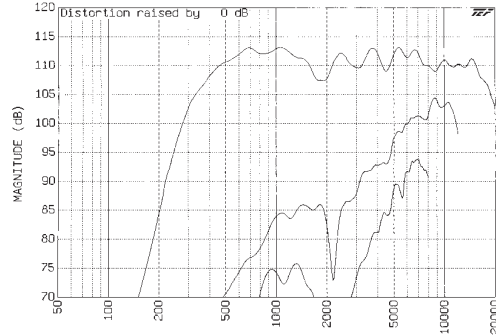

Beamwidth (-6 dB)

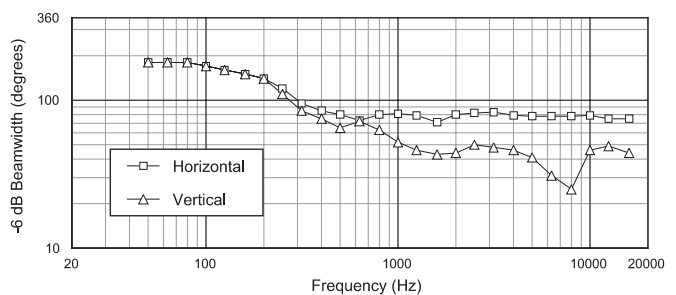

JBL Professional
8500 Balboa Boulevard, P.O. Box 2200
Northridge, California 91329 U.S.A.

■ A Harman International Company

SS 5674
CRP 15M
1/97
Rev 8/97

JBL continually engages in research related to produce improvement. New materials, production methods, and design refinements are introduced into existing products without notice as a routine expression of that philosophy. For this reason, any current JBL product may differ in some respect from its published description, but will always equal or exceed the original design specifications unless otherwise stated.